

Advantage

Hybrid / Silver Series by Ebtron

Installation, Operation and Maintenance Technical Manual

HF1/SF1

Adjustable Fan Inlet Sensors

For use with Hybrid HTx104 and Silver STx104 Series Transmitters

Includes Analog output models: HTA104-F and STA104-F
Includes RS-485 output models: HTN104-F and STN104-F
Document Name: TM_HF1_SF1_R1G



Typical Throat Mount (left) and Face Mount (right) Applications - Single inlet fan installation shown for illustration only.

TM_HF1_SF1_R1G

HYBRID SERIES
TECHNICAL MANUAL

SILVER SERIES
TECHNICAL MANUAL

LIST OF EFFECTIVE AND CHANGED PAGES

Insert latest changed pages (in bold text); remove and dispose of superseded pages.
Total number of pages in this manual is **8**.

Page No	Revision *	Description of Change	Date
1, 2	R1G	Added part number; updated document revision to R1G	03/19/2009
3 through 7	R1F	No change from initial Document Release	11/04/2008
8	R1F	Added offset dimension on face mount rods	02/9/2009

* Original blank pages 2 and 10 deleted.
Entire document reissued as revision R1F.
R1F indicates an original page without change.

Copyright © 2009 EBTRON®, Inc.
All brand names, trademarks and registered trademarks are the property of their respective owners. Information contained within this document is subject to change without notice. Visit EBTRON.com to view and/or download the most recent versions of this and other documents.
All rights reserved.

Table of Contents

OVERVIEW4

SPECIFICATIONS4

ADVANCED TECHNOLOGY4

APPLICATIONS4

SELECTION OF MOUNTING STYLES5

 Throat Mount Sensor Placement Guide5

 Centrifugal Fans - Throat Mount5

 Vane Axial Fans - Throat Mount5

 Face Mount Sensor Placement Guide5

 Plenum Fans - Face Mount5

INSTALLATION OF THROAT MOUNT AND FACE MOUNT SENSORS5

 Throat Mount Sensor Installation6

 Face Mount Sensor Installation7

MAINTENANCE8

STANDARD LIMITED PARTS WARRANTY8

MECHANICAL DIMENSIONS8

List of Figures

Figure 1. HF1/SF1 Fan Inlet Sensor Applications - Throat Mount (left) and Face Mount (right)4

Figure 2. Centrifugal Fan Throat Mount5

Figure 3. Vane Axial Fan Throat Mount5

Figure 4. Plenum Fan Face Mount5

Figure 5. Throat Mount Detail6

Figure 6. Face Mount Sensor Detail7

Figure 7. Throat Mount Sensor Detail Drawing8

Figure 8. Face Mount Sensor Detail Drawing8

List of Tables

Table 1. Throat Mount Standard Sizes5

Table 2. Face Mount Standard Sizes5

Table 3. Throat Mount Dimension 'L'6

Table 4. Face Mount Dimension "X" Determination7

TM_HF1_SF1_R1F

OVERVIEW

HF1/SF1 thermal dispersion fan inlet sensors (Figure 1) are designed for face or throat mounting in centrifugal, vane axial and plenum fans. A Throat Mount version is available for mounting directly in the inlet bell of centrifugal fans or upstream of the propeller in vane axial fans. A Face Mount version is available for sensitive plenum fan applications. The streamline design of the sensor does not adversely affect fan performance like other, more cumbersome inlet sensors.

HF1/SF1 fan inlet sensors use two “bead-in-glass” thermistors to determine the airflow rate and temperature at each sensing location. Accuracy is percent of reading (not percent of full scale). Performance is assured throughout the entire calibrated range. Sensors are connected to an HTx104 or STx104 transmitter that sums individual airflow and temperatures prior to averaging and outputs to your host control system.

HF1/SF1 fan inlet sensors are ideal for fan tracking applications, especially when duct configuration limits the use of -P duct and plenum probes.

SPECIFICATIONS

Sensor Configurations

- Single inlet (probes x sensors/probe): 2x1 (independent sensors)
- Dual inlet (probes x sensors/probe): 4x1 (independent sensors)

Sensor Accuracy

- Airflow rate: $\pm 2\%$ of reading, $\pm 0.25\%$ repeatability
- Temperature: $\pm 0.15^\circ\text{F}$ ($\pm 0.08^\circ\text{C}$)

Sensor Ranges

- Airflow rate: 0 to 10,000 fpm (0 to 50.8 m/s)
- Temperature: -20°F to 160°F (-28.9°C to 71.1°C)
- Humidity: 0 to 99% rh, non-condensing

Sensor Assembly (each sensing point)

- Heated element: One bead-in-glass, hermetically sealed, thermistor
- Temperature sensor: One bead-in-glass, hermetically sealed, thermistor
- Sensor housing: Glass-filled polypropylene
- Sensor potting material: Marine grade, waterproof epoxy

Standard Size Ranges

- 11 in. to 64 in. (279.4 mm to 1625.6 mm)

Construction

- Sensor Mounting Block: 304 stainless steel
- Rod Construction: Adjustable length, cadmium plated rods
- Mounting Feet: 304 stainless steel

Cable Assembly

- Type: UL® Plenum Rated, PVC jacket
- Length: 10 ft [std.] (3.048 m), 50 ft (15.24 m) max.
- Termination: 0.625 in. circular DIN (15.875 mm) plug [transmitter end]

“Plug and Play” Sensors

- Sensors do not require matching to transmitter

Compatible Transmitters

- Hybrid Series HTA104 / HTN104
- Silver Series STA104 / STN104

Warranty

- 36 months from shipment



Figure 1. HF1/SF1 Fan Inlet Sensor Applications - Throat Mount (left) and Face Mount (right)

ADVANCED TECHNOLOGY

- **EBTRON** Advanced Thermal Dispersion (TD) airflow measurement technology ensures accurate, repeatable measurement from zero flow (still air).
- Each sensor is factory calibrated to NIST-traceable standards.
- Mounts directly in the throat inlet of centrifugal or vane axial fans, and on the face of more sensitive plenum fans.
- True average independent, multi-point sensors.
- Highest quality and stability hermetically sealed “bead-in-glass” thermistors.
- Exclusive “Plug and Play” SMART sensor design with provision for up to 4 airflow sensors.
- Versatile mounting options for placement in the most challenging field locations.

APPLICATIONS

- Volumetric airflow rate fan tracking.
- Building pressurization control.
- Monitoring air changes.
- Temperature and humidity control.

SELECTION OF MOUNTING STYLES

HF1/SF1 sensors are available in traditional Throat Mount versions for centrifugal and vane axial fan applications, and in a new Face Mount version for more sensitive plenum fan applications.

HF1/SF1 fan inlet sensors are designed for use with HTx104 and STx104 transmitters. Sensors are available for either single or dual inlet fan installations. Single inlet applications are designated HTx104-F/SI for the Hybrid, and STx104-F/SI for the Silver Series. Dual inlet configurations are designated HTx104-F/DI for the Hybrid, and STx104-F/DI for the Silver Series. Each fan inlet uses two adjustable length sensors. Six standard sizes are available as shown in Table 1 for Throat Mount, and Table 2 for Face Mount.

Throat Mount Sensor Placement Guide

Centrifugal Fans - Throat Mount

Locate the sensors in the narrowest portion of the inlet cone as indicated in Figure 2 for the most reliable performance.

Vane Axial Fans - Throat Mount

Locate the sensors upstream of the fan blades as illustrated in Figure 3.

Face Mount Sensor Placement Guide

Plenum Fans - Face Mount

Locate the sensor on the flat face portion of the inlet bell, as shown in Figure 4. Note that the inlet **FLAT FACE** diameter "D", is measured at the **flat portion of the flat face of the inlet** at the point where the inlet flare just begins.

INSTALLATION OF THROAT MOUNT AND FACE MOUNT SENSORS

The following paragraphs detail installation of the Throat Mount and Face Mount sensors. Measurement of the fan inlet diameter is instrumental in ensuring the best performance from the airflow measurement station.

Please read and understand all Cautions/Warnings and installation steps prior to mounting the sensors. The sensors must always be installed in pairs at a fan inlet, and must be installed at the specified locations, and in parallel with one another.

Check for obstructions of the fan inlet prior to installation. It may be necessary to rotate the orientation of the sensors in order to clear obstacles in the fan inlet.

For specific installation questions, concerns or assistance, please contact **EBTRON** Applications Engineering Team at 800.2EBTRON (800.232-8766).

Table 1. Throat Mount Standard Sizes

Standard Size Code	Inlet Diameter				Rod 4 Pack Part Number
	is greater than or equal to		and is less than		
	inches	mm	inches	mm	
1	11	279.40	14	355.60	700-3055
2	14	355.60	17	431.80	700-3056
3	17	431.80	29	736.60	700-3057
4	29	736.60	43	1092.20	700-3058
5	43	1092.20	57	1447.80	700-3059
6	57	1447.80	64	1625.60	700-3060

Table 2. Face Mount Standard Sizes

Standard Size Code	Inlet Face Diameter				Rod 4 Pack Part Number
	is greater than or equal to		and is less than		
	inches	mm	inches	mm	
1	11	279.40	13	330.20	700-4055
2	13	330.20	18	457.20	700-4056
3	18	457.20	23	584.20	700-4057
4	23	584.20	32	812.80	700-4058
5	32	812.80	46	1168.40	700-4059
6	46	1168.40	64	1625.60	700-4060

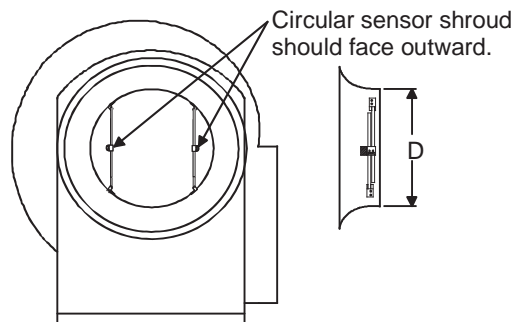

Figure 2. Centrifugal Fan Throat Mount

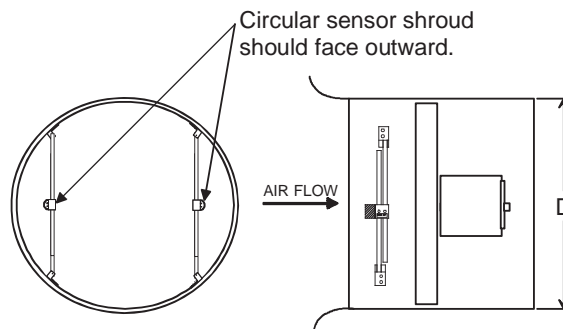
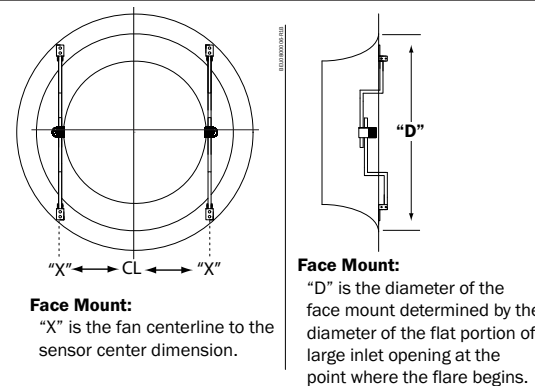

Figure 3. Vane Axial Fan Throat Mount



Face Mount:
"X" is the fan centerline to the sensor center dimension.

Face Mount:
"D" is the diameter of the face mount determined by the diameter of the flat portion of large inlet opening at the point where the flare begins.

Figure 4. Plenum Fan Face Mount

CAUTIONS/WARNINGS

Throat Mount Sensor Installation

1. Physically locate the fan indicated on the engineer's plans where the air flow measuring station is to be installed.
2. Measure the diameter ("D") of the inlet of the fan where the sensor assemblies will be installed as shown in Figures 2 and 3.
3. Refer to Table 1 to verify that the proper sensors and rods have been received.
3. Insert one mounting rod into the outer most sensor rod hole so that the widest portion of the mounting foot is towards the center of the sensor housing as shown in Figure 5.
4. Insert a second mounting rod from opposite direction into the inner most hole as shown in Figure 5.
5. Locate **DIMENSION "L"** in Table 3 to determine the setup distance, "L", measured from roll pin to sensor set screws.
6. Adjust inner and outer rods so that the distance between the roll pin of each foot and the set screws on the mounting block is equal to "L".
7. Tighten the set screws using the hex wrench provided.
8. Repeat Steps 3 thru 7 for each of the sensor assemblies. Sensors are now ready for installation.
9. Install the sensor assembly labeled "inside left" into the left side of the fan inlet with the sensor shroud pointing outward. Select suitable hardware for the installation and ensure that the screws do not hinder rotation of the fan.
10. Install the sensor assembly labeled "inside right" into the right side of the fan inlet with the sensor shroud pointing outward.
11. Strap down sensor cables to the mounting rods using the tie wraps provided (two tie wraps per sensor).
12. Secure the cables with appropriate hardware.
13. Route sensor cables to the area where the transmitter will be located. Sensor installation is complete. Refer to the separate transmitter technical manual for connection and set up.

- Setting the specified rod length is essential for proper installation and sensor performance.
- Failure to setup and/or properly secure the HF1/SF1 sensor assembly can result in sensor and/or fan damage.
- Improper lubrication of the fan bearings can result in oil carry over and material buildup on the sensor.
- The cable length ordered must be long enough to accommodate the distance between the transmitter and the furthest sensor.
- Select suitable hardware for the installation and make sure that the screws will not interfere with rotation of the fan.
- Avoid placement in the absorption area of humidifiers as this will adversely affect performance.

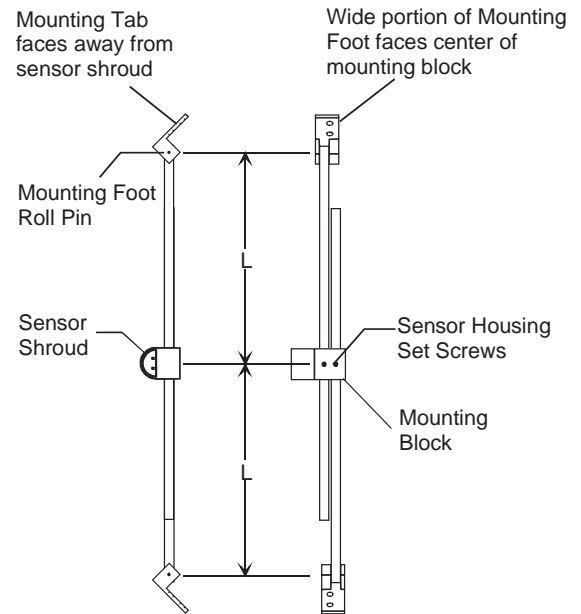

Figure 5. Throat Mount Detail

Table 3. Throat Mount Dimension 'L'

Inlet Diameter "D" (in.)	L (in.)	Inlet Diameter "D" (mm)	L (mm)	Inlet Diameter "D" (in.)	L (in.)	Inlet Diameter "D" (mm)	L (mm)	Inlet Diameter "D" (in.)	L (in.)	Inlet Diameter "D" (mm)	L (mm)
11	3 11/16	279.40	93.84	29	11 1/4	736.60	286.25	47	18 7/8	1193.80	478.66
12	4 1/8	304.80	104.53	30	11 11/16	762.00	296.94	48	19 1/4	1219.20	489.35
13	4 9/16	330.20	115.22	31	12 1/8	787.40	307.63	49	19 11/16	1244.60	500.04
14	4 15/16	355.60	125.91	32	12 1/2	812.80	318.32	50	20 1/8	1270.00	510.73
15	5 3/8	381.00	136.59	33	12 15/16	838.20	329.01	51	20 1/2	1295.40	521.42
16	5 13/16	406.40	147.28	34	13 3/8	863.60	339.70	52	20 15/16	1320.80	532.11
17	6 1/4	431.80	157.97	35	13 13/16	889.00	350.39	53	21 3/8	1346.20	542.80
18	6 5/8	457.20	168.66	36	14 3/16	914.40	361.08	54	21 13/16	1371.60	553.49
19	7 1/16	482.60	179.35	37	14 5/8	939.80	371.77	55	22 3/16	1397.00	564.18
20	7 1/2	508.00	190.04	38	15 1/16	965.20	382.46	56	22 5/8	1422.40	574.87
21	7 7/8	533.40	200.73	39	15 1/2	990.60	393.15	57	23 1/16	1447.80	585.56
22	8 5/16	558.80	211.42	40	15 7/8	1016.00	403.83	58	23 8/16	1473.20	596.25
23	8 3/4	584.20	222.11	41	16 5/16	1041.40	414.52	59	23 7/8	1498.60	606.94
24	9 3/16	609.60	232.80	42	16 3/4	1066.80	425.21	60	24 5/16	1524.00	617.63
25	9 9/16	635.00	243.49	43	17 3/16	1092.20	435.90	61	24 3/4	1549.40	628.32
26	10	660.40	254.18	44	17 9/16	1117.60	446.59	62	25 3/16	1574.80	639.01
27	10 7/16	685.80	264.87	45	18	1143.00	457.28	63	25 9/16	1600.20	649.70
28	10 7/8	711.20	275.56	46	18 7/16	1168.40	467.97	64	26	1625.60	660.38







L = distance between locking set screw at sensor housing and mounting foot roll pin

TM_HF1_SF1_R1F

Face Mount Sensor Installation

1. Physically locate the fan where the air flow measuring station is to be installed on the engineer's plans.
2. Use the hex wrench provided to loosen the sensor housing set screws on the sensor mounting block as shown in Figure 6.
3. Insert an 'inner mounting rod' (attached to inner roll pin on bracket) into the sensor mounting block 'inner rod hole' as shown in Figure 6.
4. Similarly, insert an 'outer mounting rod' (attached to outer roll pin on bracket) into the sensor mounting block 'outer rod hole' as shown in Figure 6.
5. Repeat Steps 2 through 4 for each of the sensor assemblies.
6. Measure the diameter ('D') of the fan inlet **FLAT FACE**, measured at the **flat portion of the flat face of the inlet** at the point **where the inlet flare just begins**.
7. Using Diameter 'D', locate DIMENSION "X" in Table 4 to determine the fan inlet center line to sensor mounting center line for each sensor as shown in Figure 6.
8. While holding the brackets at Dimension "X", adjust the inner and outer rods so that the distance between the set screws on the mounting block and the roll pin of each mounting foot bracket is equal. Tighten the set screws using the hex wrench provided. Sensors are now ready for installation.
9. Install the sensor assembly labeled "inside left" onto the left side of the flat face of the fan inlet as shown in Figure 6. Select suitable hardware for installation, making sure that the screws do not hinder the rotation of the fan.
10. Install the sensor assembly labeled "inside right" onto the right side of the flat face of the fan inlet as shown in Figure 6. Select suitable hardware for installation, making sure that the screws do not hinder the rotation of the fan.
11. Strap down sensor cables to mounting rods using the tie wraps provided (two tie wraps per sensor), and secure the cables with appropriate hardware.
12. Route sensor cables to the area where the transmitter will be located. Sensor installation is complete. Refer to the separate transmitter technical manual for connection and set up.

CAUTIONS/WARNINGS

-  Setting the specified rod length is essential for proper installation and sensor performance.
-  Failure to setup and/or properly secure the HF1/SF1 sensor assembly can result in sensor and/or fan damage.
-  Improper lubrication of the fan bearings can result in oil carry over and material buildup on the sensor.
-  The cable length ordered must be long enough to accommodate the distance between the transmitter and the furthest sensor.
-  Select suitable hardware for the installation and make sure that the screws will not interfere with rotation of the fan.
-  Avoid placement in the absorption area of humidifiers as this will adversely affect performance.

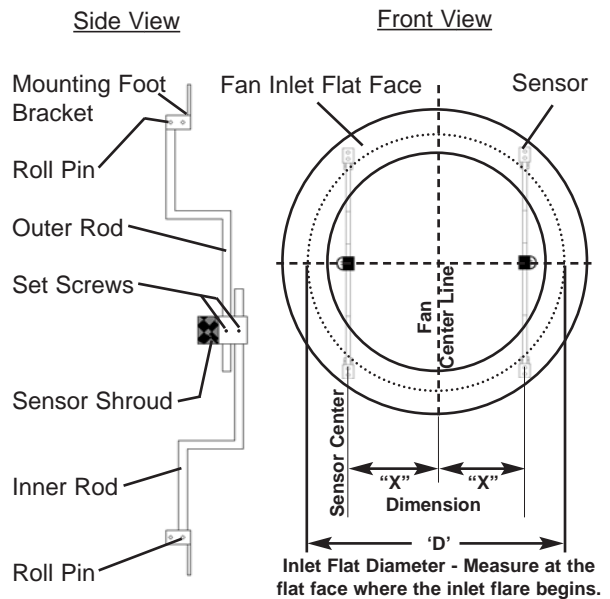

Figure 6. Face Mount Sensor Detail

Table 4. Face Mount Dimension "X" Determination

Inlet Diameter "D" (in.)	X (in.)	Inlet Diameter "D" (mm)	X (mm)	Inlet Diameter "D" (in.)	X (in.)	Inlet Diameter "D" (mm)	X (mm)	Inlet Diameter "D" (in.)	X (in.)	Inlet Diameter "D" (mm)	X (mm)
11	3 3/8	279.40	86.08	29	9 3/4	736.60	247.73	47	16 1/8	1193.80	409.37
12	3 3/4	304.80	95.06	30	10 1/8	762.00	256.71	48	16 1/2	1219.20	418.35
13	4 1/8	330.20	104.04	31	10 7/16	787.40	265.69	49	16 13/16	1244.60	427.33
14	4 7/16	355.60	113.02	32	10 13/16	812.80	274.67	50	17 3/16	1270.00	436.31
15	4 13/16	381.00	122.00	33	11 3/16	838.20	283.65	51	17 1/2	1295.40	445.29
16	5 3/16	406.40	130.98	34	11 1/2	863.60	292.63	52	17 7/8	1320.80	454.27
17	5 1/2	431.80	139.96	35	11 7/8	889.00	301.61	53	18 1/4	1346.20	463.25
18	5 7/8	457.20	148.94	36	12 1/4	914.40	310.59	54	18 9/16	1371.60	472.23
19	6 3/16	482.60	157.92	37	12 9/16	939.80	319.57	55	18 15/16	1397.00	481.21
20	6 9/16	508.00	166.91	38	12 15/16	965.20	328.55	56	19 5/16	1422.40	490.19
21	6 15/16	533.40	175.89	39	13 5/16	990.60	337.53	57	19 5/8	1447.80	499.17
22	7 1/4	558.80	184.87	40	13 5/8	1016.00	346.51	58	20	1473.20	508.15
23	7 5/8	584.20	193.85	41	14	1041.40	355.49	59	20 3/8	1498.60	517.14
24	8	609.60	202.83	42	14 3/8	1066.80	364.47	60	20 11/16	1524.00	526.12
25	8 5/16	635.00	211.81	43	14 11/16	1092.20	373.45	61	21 1/16	1549.40	535.10
26	8 11/16	660.40	220.79	44	15 1/16	1117.60	382.43	62	21 7/16	1574.80	544.08
27	9 1/16	685.80	229.77	45	15 7/16	1143.00	391.41	63	21 3/4	1600.20	553.06
28	9 3/8	711.20	238.75	46	15 3/4	1168.40	400.39	64	22 1/8	1625.60	562.04

"D" Inlet Diameter Must be Measured Across Flat Face at Flare Edge - See Text

"X" = Distance Between Fan Center Line and Sensor Center Line.

MAINTENANCE

In most HVAC environments, periodic calibration is neither required or recommended¹.

STANDARD LIMITED PARTS WARRANTY

If any **EBTRON** product fails within 36 months from shipment, **EBTRON** will repair/replace the device free of charge as described in the company's warranty contained in **EBTRON's TERMS AND CONDITIONS OF SALE**. Defective equipment shall be shipped back to **EBTRON**, freight pre-paid, for analysis.

MECHANICAL DIMENSIONS

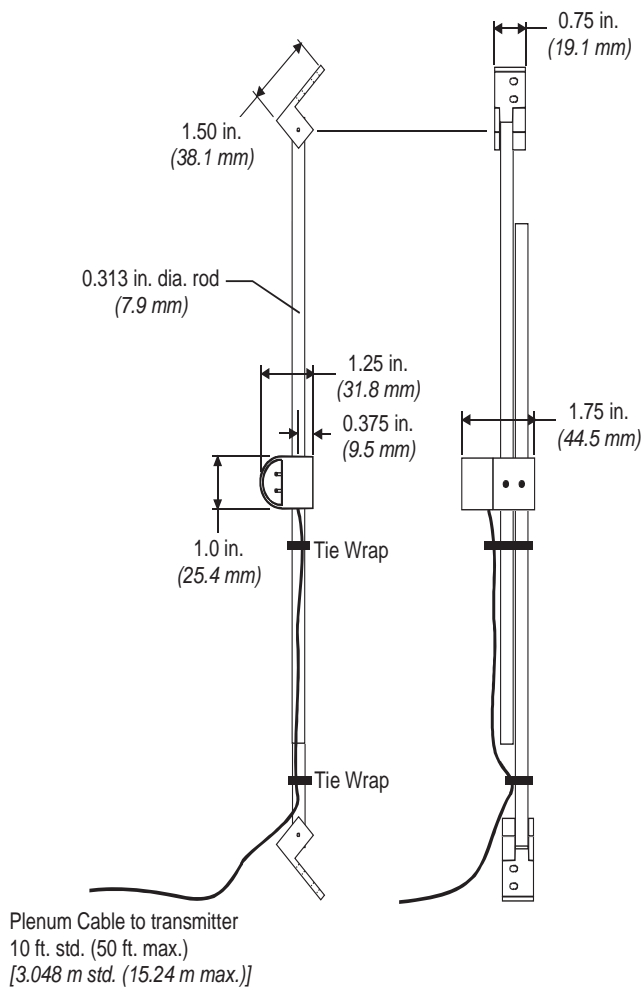

Figure 7. Throat Mount Sensor Detail Drawing

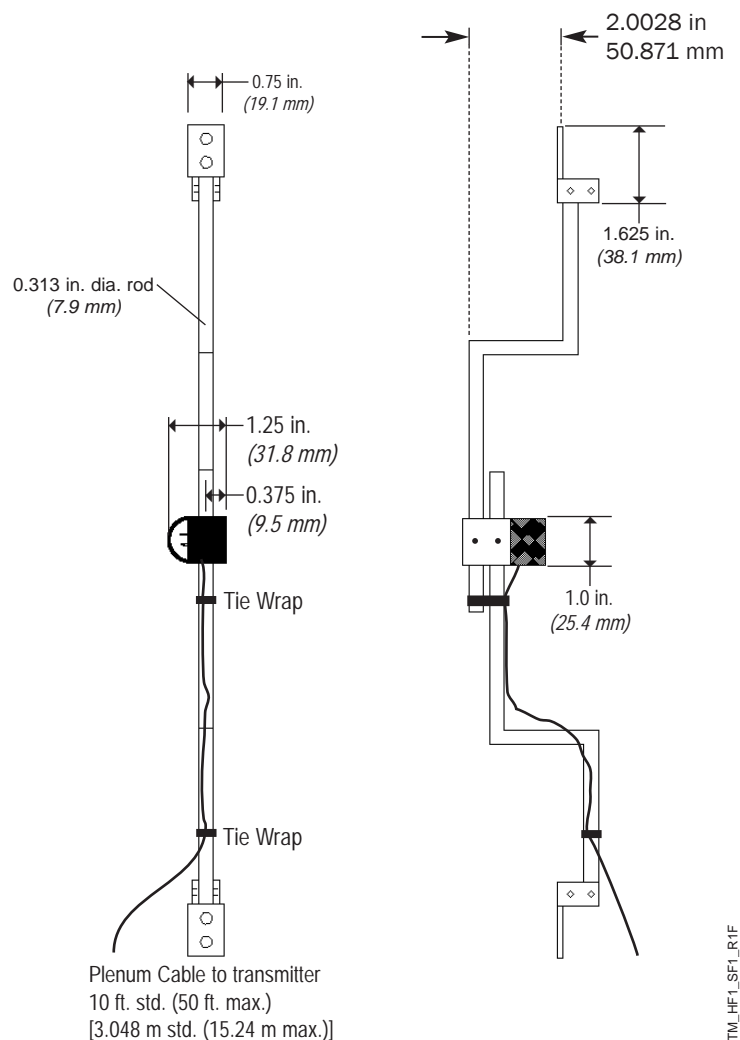

Figure 8. Face Mount Sensor Detail Drawing

¹In certain applications where a large amount of airborne particulate is present, especially fibrous material such as lint, pre-filtering of the return air (using MERV 5 or equivalent filter) may be required to ensure optimum instrument performance. If no pre-filtering is provided, it may be necessary to periodically inspect and clean sensors using compressed air or a small brush. Factory performance returns immediately after cleaning. Recalibration is NOT required. Periodic inspection of the sensors is always advised, and accessibility must be considered in these applications.