

Advantage

Silver Series by Ebtron

Installation, Operation and Maintenance Technical Manual

SU1

Unit Ventilator Airflow Sensors

For use with Silver Series STx104-U Transmitters

Includes Analog output models: STA104-U and
RS-485 network output models: STN104-U

Document Name: *TM_SU1_R1B*



TM_SU1_R1B

SILVER SERIES
TECHNICAL MANUAL

LIST OF EFFECTIVE AND CHANGED PAGES

Insert latest changed pages (in bold text); remove and dispose of superseded pages.
Total number of pages in this manual is **6**.

Page No	Revision *	Description of Change	Date
1, 2	R1B	Added part number, updated revision to R1B	03/19/2009
3 through 8	R1A	Initial Document Release	12/12/2008

* R1A indicates an original page without change

Table of Contents

OVERVIEW3
 SPECIFICATIONS3
 ADVANCED TECHNOLOGY3
 APPLICATIONS3
 SU1 SENSOR PROBE PLACEMENT4
 SU1 Minimum Placement Guidelines4
 SU1 SENSOR PROBE INSTALLATION5
 SU1 MAINTENANCE6
 SU1 STANDARD LIMITED PARTS WARRANTY6

List of Figures

Figure 1. SU1 Unit Ventilator Sensor4
 Figure 2. SU1 Unit Ventilator Sensor Probe Minimum Placement Guidelines5
 Figure 3. SU1 Unit Ventilator Sensor Probe Mechanical Dimensions6

TM_SU1_R1B

Copyright © 2008, EBTRON®, Inc.
 All brand names, trademarks and registered trademarks are the property of their respective owners. Information contained within this document is subject to change without notice. Visit EBTRON.com to view and/or download the most recent versions of this and other documents.
 All rights reserved.

OVERVIEW

The **EBTRON Silver Series SU1** airflow sensor probes are designed for continuous measurement and precise control of outdoor air intake flow rates for dilution air control, ASHRAE[®] 62.1 compliance and LEED[®] credit acquisition. SU1 sensor probes are an integral part of the **EBTRON STx104-U** Unit Ventilator Airflow Measurement Station.

SU1 sensor airflow accuracy is $\pm 2\%$ of reading, and temperature accuracy is $\pm 0.15^\circ\text{F}$ when installed in accordance with **EBTRON** minimum placement guidelines. Accuracy is a function of the velocity profile at the intake and is ensured through individual sensor characterization at 16 points over the range of 0 to 5,000 fpm (0 to 25.4 m/s) in wind tunnels calibrated to NIST-traceable volumetric airflow standards. Sensor element calibration data is embedded within each "smart" sensor probe assembly. Accuracy is a "percent of reading" and not a "percent of full scale", which is common with other airflow instruments resulting in poor accuracy and performance, particularly at low airflow levels.

EBTRON uses high quality precision "**bead-in-glass**" thermistor sensor elements to determine airflow rate and temperature. The sensors relate heated element thermal transfer rate to airflow rate. As velocity increases across the sensor, so does thermal transfer rate.

A unique integral 304 stainless steel bracket permits simple field installation in a variety of unit ventilator applications.

Periodic field calibration/maintenance of the SU1 is not required in most environments.

SPECIFICATIONS

SU1 Sensor Probe Specifications

Sensor Assembly Model:	SU1
Sensor Assembly:	Two hermetically sealed "bead-in-glass" thermistors in a GFP housing
Mounting Brackets:	Type 304 S/S
Probe Size:	4 to 12 inches
Cable Assembly:	
Type:	Plenum rated PVC
Length:	5feet std. (up to 50feet opt.)
Connection to Transmitter:	5/8-inch circular DIN connectors
Air Velocity Calibration Points:	16
Temperature Calibration Points:	3
Number of Sensors/Probe:	1
Sensor Distribution:	<u>Equal area</u>
Airflow Sensor Accuracy:	$\pm 2\%$ of reading
Calibrated Range:	0-5,000 fpm
Temperature Sensor Accuracy:	0.15 $^\circ\text{F}$
Sensor Temperature Range:	
0-1,500 fpm:	-20 $^\circ\text{F}$ to 160 $^\circ\text{F}$
>1,500 fpm:	30 $^\circ\text{F}$ to 160 $^\circ\text{F}$
Humidity range:	0 to 99% RH, non-condensing

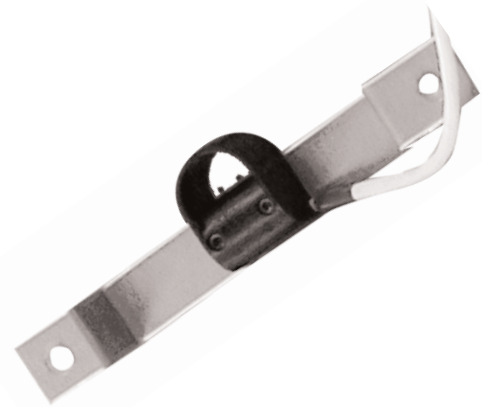

Figure 1. SU1 Unit Ventilator Sensor

ADVANCED TECHNOLOGY

- **EBTRON** Advanced Thermal Dispersion (TD) airflow measurement technology ensures accurate, repeatable measurement from zero flow (still air).
- 16 point factory calibration of each sensor to **NIST-traceable** volumetric airflow standards.
- True volumetric airflow rate using independent multi-point sensors.
- Superior performance compared to conventional differential pressure-based pitot arrays and flow rings.
- Highest quality stable hermetically sealed "**bead-in-glass**" thermistors.
- Exclusive "**Plug and Play**" SMART sensor design.
- Integral 304 Stainless Steel bracket for simple field installation.

APPLICATIONS

- High accuracy airflow measurement in unit ventilators for direct measurement and precise control of outdoor air intake flow for dilution air control.
- Ideal for direct outdoor airflow measurement and continuous reset of intake flow rates for true demand controlled ventilation compliance with **ASHRAE 62.1-2007**, **LEED Credit EQc1 for Monitoring of Outdoor Air Delivery** and **EQc2 for Increased Ventilation**.

¹ In certain applications where a large amount of airborne particulate is present, especially fibrous material such as lint, pre-filtering of the return air (using MERV 5 or equivalent filter) may be required to ensure optimum instrument performance. If no pre-filtering is provided, it may be necessary to periodically inspect and clean sensors using compressed air or a small brush. Factory performance returns immediately after cleaning. Recalibration is NOT required. Periodic inspection of the sensors is always advised, and accessibility must be considered in these applications.

SU1 SENSOR PROBE PLACEMENT



EBTRON SU1 thermal dispersion probes are designed to be mounted upstream of the outdoor air intake damper within approved unit ventilators in locations that were traditionally problematic for other airflow measurement technologies. Contact **EBTRON** or your local **EBTRON** Representative for a current list of approved ventilators, or with assistance with specific applications.

The SU1 is available in a dual probe configuration providing a total of two sensors per intake. Probes are designed to fit in a 4 to 12 inch opening of approved unit ventilators. The following paragraphs detail the procedure required for determining optimum placement of SU1 sensor probes in approved unit ventilator applications.

CAUTION



Installation of SU1 probes at the location specified in the Minimum Placement Guidelines that follow is critical for proper performance of the airflow measurement station.



Although SU1 sensor probes are water resistant, avoid locating airflow measurement stations where they will be subject to frequent water exposure.



The installed accuracy compared to field verification techniques can be improved by using the field-adjustable gain feature. Note that field verification results typically yield measurement uncertainties of 5% to 10% of reading depending upon the equipment used, measurement technique, and expertise of the verification technician.

SU1 Minimum Placement Guidelines

SU1 unit ventilator sensor probes are computer calibrated at 16 points between 0 and 5,000 fpm (0 and 25.4 m/s) in individual wind tunnels to volumetric airflow standards. Placement of the SU1 sensor probes is critical for proper operation and accuracy of the airflow measurement station. Figure 2 shows minimum placement requirements for the SU1 sensor probes in approved unit ventilators. As shown, the probes are located at $X/4$ from each end (left and right), and $X/2$ from one another on the inside of the unit ventilator outdoor air intake, where X = the overall width of the outdoor air intake opening. Note that the round sensor shrouds on the sensors face away from one another.

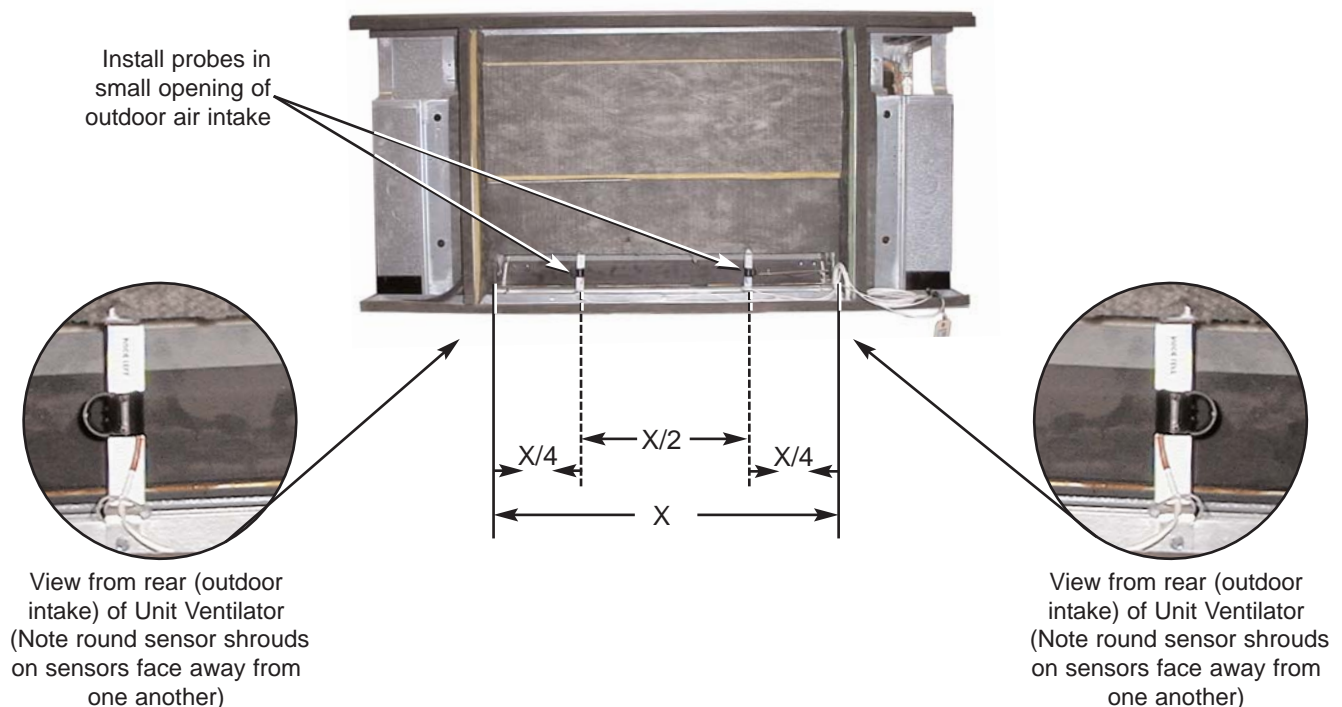

Figure 2. SU1 Unit Ventilator Sensor Probe Minimum Placement Guidelines

SU1 SENSOR PROBE INSTALLATION

SU1 unit ventilator sensor probes include an integral 304 stainless steel bracket designed for field installation internal-ly within approved unit ventilators. Figure 3 is a mechanical detail drawing of the SU1 sensor probe.

Probes are supplied with a standard 5 foot plenum-rated cable (up to 50 feet available as an option) for connection to a remotely located STx104-U transmitter (required). Each sensor probe is connected to the transmitter with a simple, positive-locking, 5/8-inch outside diameter DIN connector. The length of the cable is measured from the end of the sensor probe and is the same length for both probes in a given location. Probes should be installed with the airflow arrow pointing in the appropriate direction and fastened with suitable hardware. Figure 3 shows the mechanical installation dimensions for the SU1 probe. Install SU1 sensor probes as follows:

CAUTION



Location of the SU1 sensor probe is critical for proper performance of the airflow station. Refer to Minimum Placement Guidelines section of this document for information on recommended location of SU1 probes.

1. Each SU1 sensor probe package is factory labeled for the location/unit ventilator for which it was designed. Determine the specific location for the SU1 sensor probe as indicated on the engineer's plans showing where the airflow measuring station probe is to be located. Probes should always be mounted vertically in the intake opening as shown in Figure 2, with the round sensor shrouds pointing away from one another and to the outside of the unit ventilator.
2. Carefully open the package and inspect for damage.
3. Locate the point on the unit ventilator or air damper where the probe will be inserted.
4. Place the probe assembly at the mounting location, oriented vertically, so that the round shroud points towards the outer sidewall of the unit ventilator and away from the round shroud of the other sensor. Ensure that the airflow arrow printed on the sensor is oriented in the direction of airflow. Fasten the mounting bracket to the duct with appropriate sheet metal screws.
5. Connect each sensor probe to the transmitter. Refer to the separate STx104 Transmitter Installation, Operation and Maintenance Technical Manual (under separate cover) for information on set up and operation of the airflow measurement system.

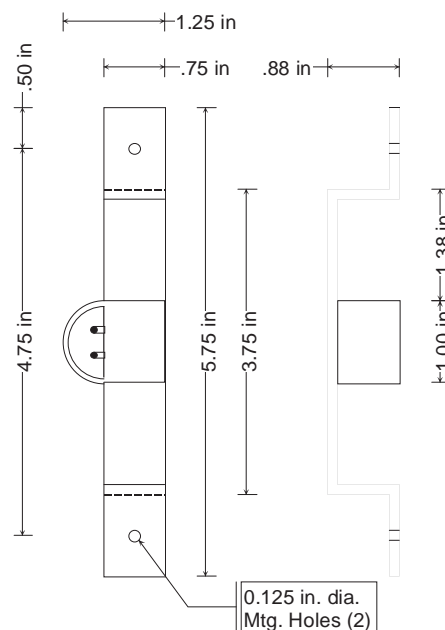

Figure 3. SU1 Unit Ventilator Sensor Probe Mechanical Dimensions

SU1 MAINTENANCE

In most HVAC environments, periodic maintenance and calibration are not required or recommended¹.

¹ In extremely dirty environments, periodic inspection of the sensor element is advised. Carefully remove any excessive buildup of material with compressed air or with a small brush. Recalibration is NOT required.

SU1 STANDARD LIMITED PARTS WARRANTY

If any **EBTRON** product fails within 36 months from shipment, **EBTRON** will repair/replace the device free of charge as described in the company's warranty contained in **EBTRON's** Terms and Conditions of Sale. Defective equipment shall be shipped back to **EBTRON**, freight pre-paid, for analysis.